

# Assembly Instructions for Trolley model no. 05307

## Before you begin:

Unpack your Trolley and make sure you have all of the following parts (**fig. 1**):

- A 4 Casters (2 locking)
- B 4  $\frac{3}{8}$ " Machine Screws
- C 2  $1\frac{1}{2}$ " Bolts
- D 1 Wrench
- E 1 Hanging File Frame
- F 1 Left Side Support
- G 1 Right Side Support
- H 3 Support Tubes
- I 1 Threaded Support Rod
- J 1 Small Allen Wrench
- K 1 Large Allen Wrench

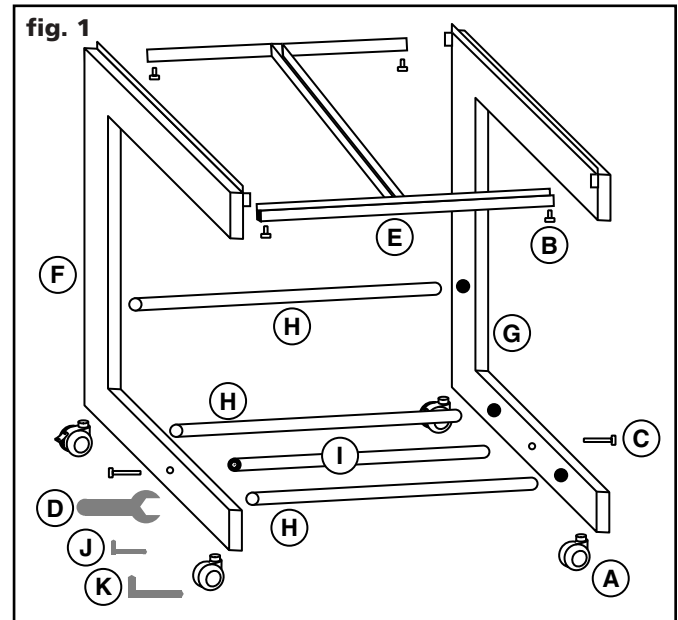

## How To Assemble Your Trolley Model No. 05307:

**SUPPORT ROD:** (**fig. 2**). Attach the Threaded Support Rod (I) to the Left Side Support (F) using one  $1\frac{1}{2}$ " Bolt (C), and the Large Allen Wrench (K). Do not tighten.

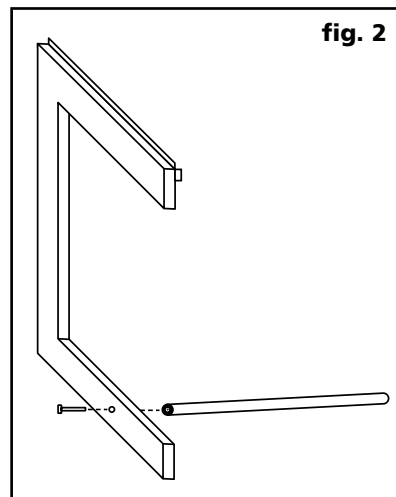

**ASSEMBLING THE FRAME:** (**fig. 3**). Lay the left side assembly on its side. Attach the Hanging File Frame (E) to the Left Side Support using two  $\frac{3}{8}$ " Machine Screws (B), using the Small Allen Wrench. Do not tighten.

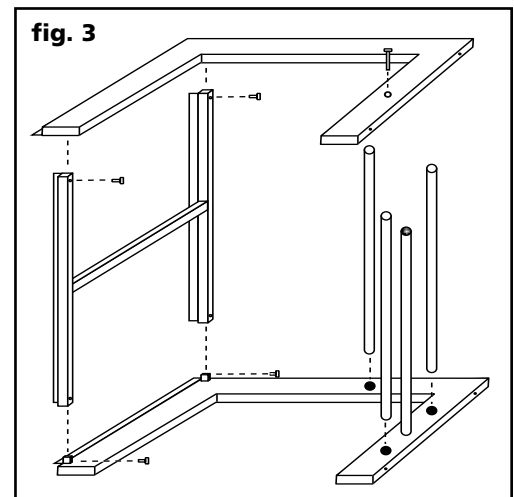

Next, insert the three Support Rods into the circular holes.

Align the Right Side Support over the Hanging File Frame, Support Rods, and Support Tube. Secure the Hanging File Frame with the remaining  $\frac{3}{8}$ " Machine Screws (B), and the Support Rod (I) with the remaining  $1\frac{1}{2}$ " Bolt (C). Do not tighten.

On a flat surface, place the Trolley on its back. Now tighten all screws securely.

**INSTALLING THE CASTERS:** Turn the unit upside down and install the Casters (A) using the Wrench (D). Make sure the two Locking Casters are toward the rear.

Your completed Trolley should look like **fig. 4**.

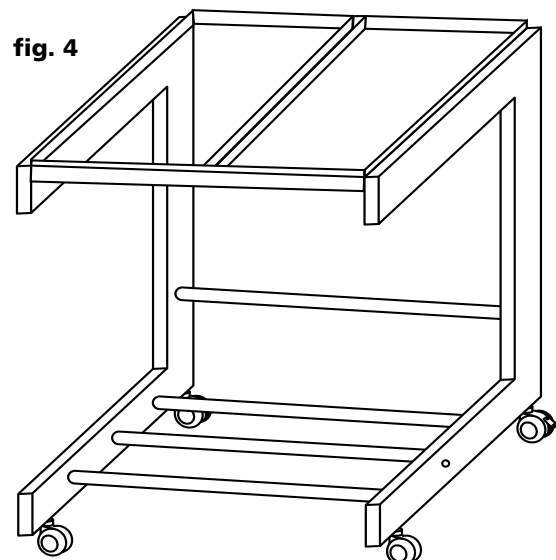

# Assembly Instructions for Trolley model no. 05308

## Before you begin:

Unpack your Trolley and make sure you have all of the following parts (**fig. 1**):

- A 4 Casters (2 locking)
- B 4  $\frac{3}{8}$ " Machine Screws
- C 2  $1\frac{1}{2}$ " Bolts
- D 1 Wrench
- E 2 Hanging File Supports
- F 1 Left Side Support
- G 1 Right Side Support
- H 3 Support Tubes
- I 1 Threaded Support Rod
- J 1 Small Allen Wrench
- K 1 Large Allen Wrench

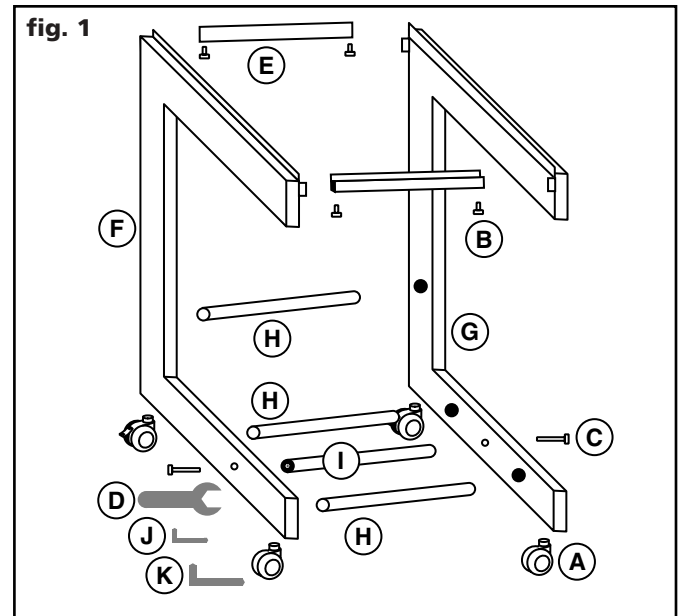

## How To Assemble Your Trolley Model No. 05308:

**SUPPORT ROD:** (**fig. 2**). Attach the Threaded Support Rod (I) to the Left Side Support (F) using one  $1\frac{1}{2}$ " Bolt (C), and the Large Allen Wrench (K). Do not tighten.

**ASSEMBLING THE FRAME:** (**fig. 3**). Lay the left side assembly on its side. Attach the Hanging File Supports (E) to the Left Side Support using two  $\frac{3}{8}$ " Machine Screws (B), using the Small Allen Wrench. Do not tighten.

Next, insert the three Support Rods into the circular holes.

Align the Right Side Support over the Hanging File Supports, Support Rods and Support Tube. Secure the Hanging File Supports with the remaining  $\frac{3}{8}$ " Machine Screws (B) and the Support Rod (I) with the remaining  $1\frac{1}{2}$ " Bolt (C). Do not tighten.

On a flat surface, place the Trolley on it's back. Now tighten all screws securely.

**INSTALLING THE CASTERS:** Turn the unit upside down and install the Casters (A) using the Wrench (D). Make sure the two Locking Casters are toward the rear.

Your completed Trolley should look like **fig. 4**.

