

Your **Kwick-View** Wall Organizer assembles easily!

This package includes:

- 1 pair of Wall Plates
- 1 pair Page Holder Brackets
- 2 Adjustment Knobs
- 10 assorted color Easy-Loading Pockets
- 2 Wall Anchors
- 2 Screws

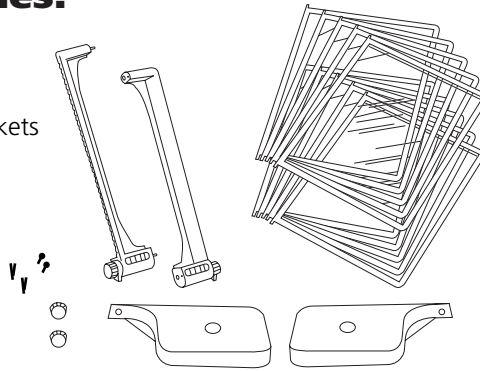

Step 1

Secure the right- and left-side Page Holder Brackets by pressing them firmly together. If you are using optional Extension Kits, separate the right- and left-side Brackets, align the Extension Brackets, and connect them all by pressing them firmly together (see fig. 1).

Step 2

Attach the Page Holder Bracket to the Wall Plates using the Adjustment Knobs. Temporarily position the Bracket in the "flat" position. Remove the screw caps from the Wall Plates. Determine the location where you want your Organizer to be mounted. Keep in mind that a 10-pocket unit requires a minimum space of 19" in width. Also, each additional Extension Kit increases width by 3". Making sure the unit is level, make light pencil marks in the center of each screw hole (see fig. 2). Using a 1/4" drill bit, drill these two holes, then tap the wall anchors into the holes using a hammer. Using the included Screws, attach the Organizer securely to the wall.

Step 3

Using the Adjustment Knobs, set the Page Holder Bracket to the desired angle and tighten Knobs securely (see fig. 3).

Step 4

Insert the Easy-Loading Pockets by flexing them slightly at the spine. Insert the pivots into the corresponding top and bottom holes. Insert up to two documents (back-to-back) into the Pockets making sure to tuck the corners of the sheet protectors under the triangular flaps. (see fig. 4).

Suggestion: For even quicker implementation of your Organizer, we suggest the pre-arranging and loading of your documents into the Pockets, then inserting the Pockets into the Page Holder Brackets.

